

Dobar dan.

Sledeći sklop koji ću vam zadati ćete raditi naredne dvije sedmice. Ko se malo posveti može sve uraditi za tri sata, ali ne želim da vas suviše opterećujem nego da polako i detaljno uradite rad. U ovoj sedmici će biti potrebno da izmodelirate sve elemente sklopa, a naredne semice da sve to sklopite.

Srećan rad.

Pozdrav.

N9

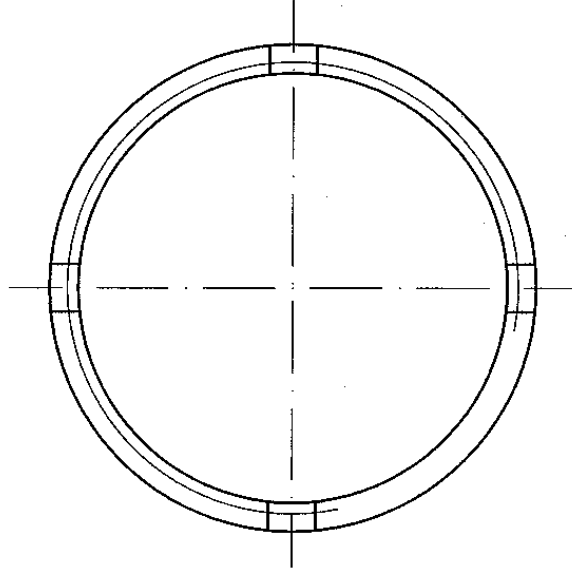
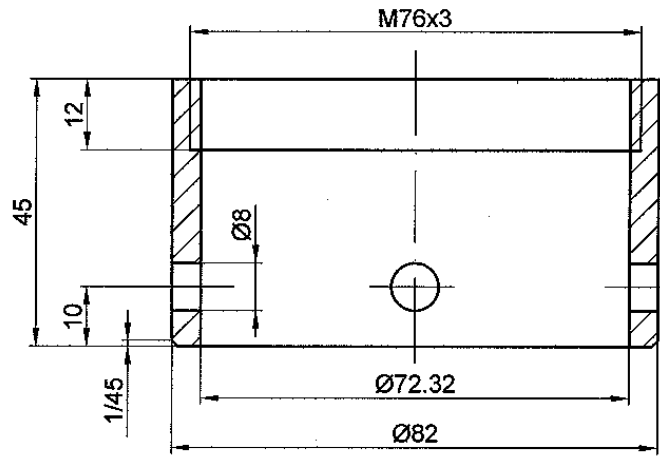

Tolerancije slobodnih mera		Površinska hrapavost		Površinska zaštita	
Materijal				Termička obrada	
				Masa	Razmera 1:1
		Datum		Naziv: Cev	
		Obradio Ivan Nikolic			
		Stand.			
		Odobrio			
				Oznaka: List:	
				L	
St. l.	Izmene	Datum	Ime	Izv. pod.	Zamena za:

Ø50 f7	-0.025 -0.050
Ø38 H7	-0.025 0
Ø36 H7	-0.025 0
Ø30 H7	-0.021 0

N9 / N6

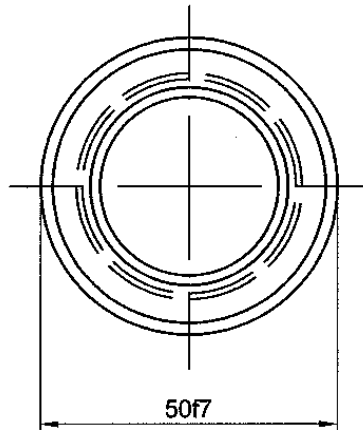
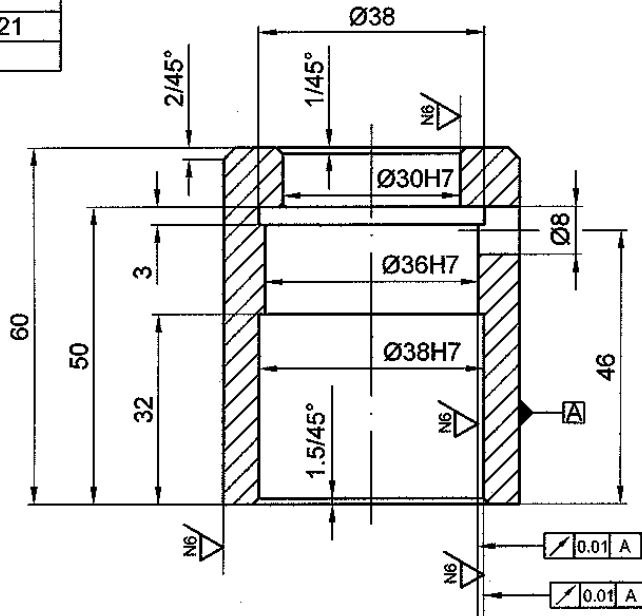

Tolerancije slobodnih mera		Površinska hrapavost		Površinska zaštita	
Materijal				Termička obrada	
		Masa		Razmera 1:1	
Datum		Naziv:		Cilindar	
Obradio Ivan Nikolic					
Stand.					
Odobrio					
St. i.		Izmene		Datum	
Ime				Oznaka:	
		MAŠINSKO ELEKTROTEHNIČKA ŠKOLA „GOŠA“		Líst:	
				L	
				Izv. pod.	
				Zamena za:	

Ø38 g7	-0.009
	-0.034
Ø15 H7	-0.018
	0

N9 / N6

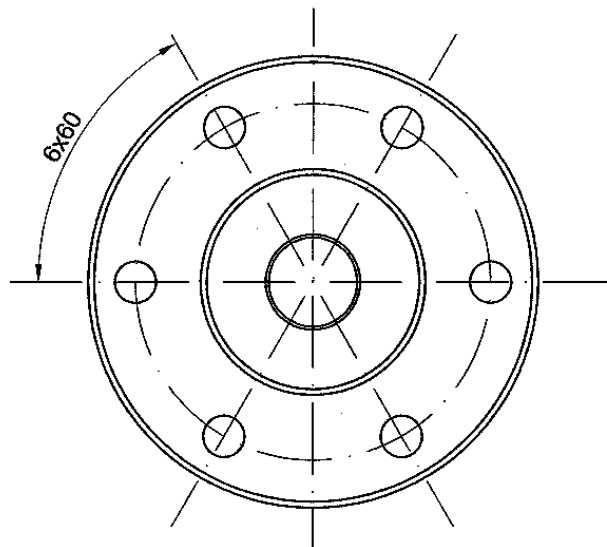
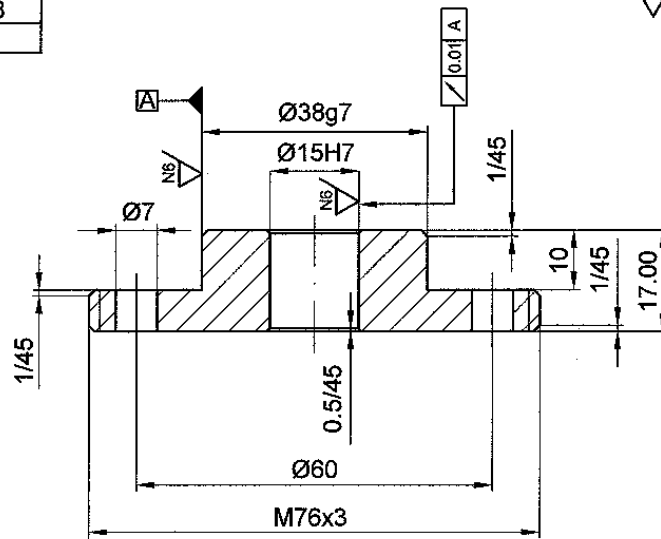

Tolerancije slobodnih mera		Površinska hrapavost		Površinska zaštita	
Materijal		Termička obrada			
		Masa		Razmera 1:1	
Datum		Naziv:			
Obradio Ivan Nikolic		POKLOPAC			
Stand.					
Odobrio					
		Oznaka:		List:	
St. i.		Izmene		L	
Datum		Ime		Izv. pod.	
				Zamena za:	

Ø36 d7	-0.080
	-0.105
Ø30 d7	-0.065
	-0.086
Ø15 d7	-0.050
	-0.068

N8 / N5 Brušeno

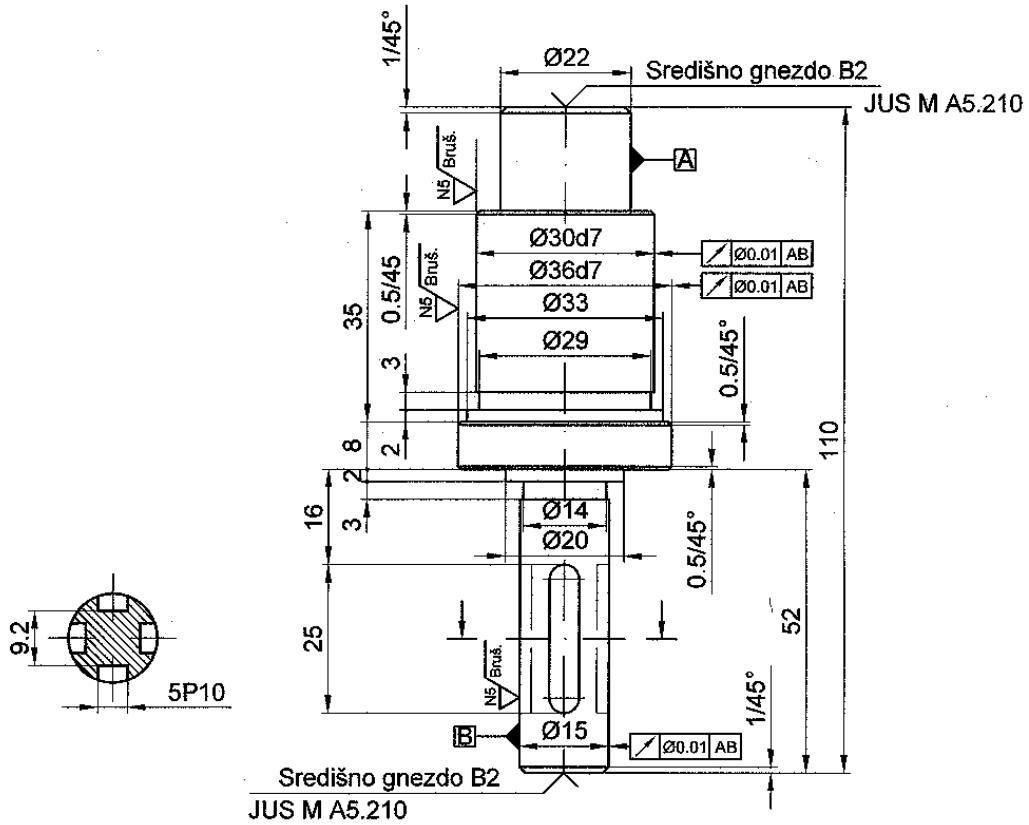

Tolerancije slobodnih mera		Površinska hrapavost		Površinska zaštita	
Materijal				Termička obrada	
		Masa		Razmera 1:1	
Datum		Obradio		Naziv:	
		Ivan Nikolic		Klip	
Stand.		Odobrio			
St. i.		Izmene		Oznaka:	
Datum		Ime		Izv. pod	
				Zamena za:	
				List:	
				L	

MAŠINSKO
ELEKTROTEHNIČKA
ŠKOLA „GOŠA“

Ø50 H8	-0.039
	0

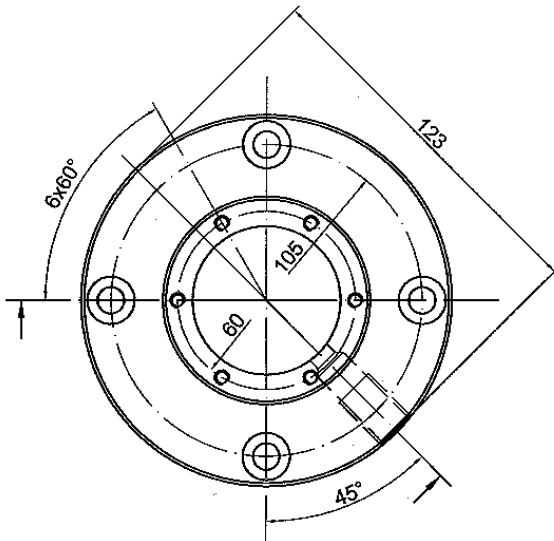
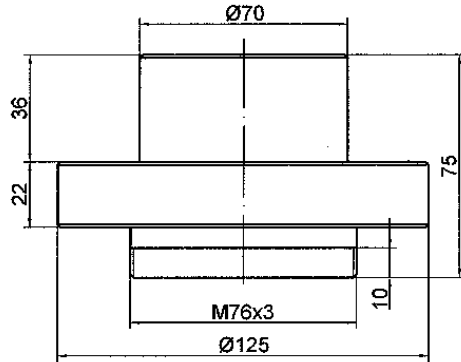
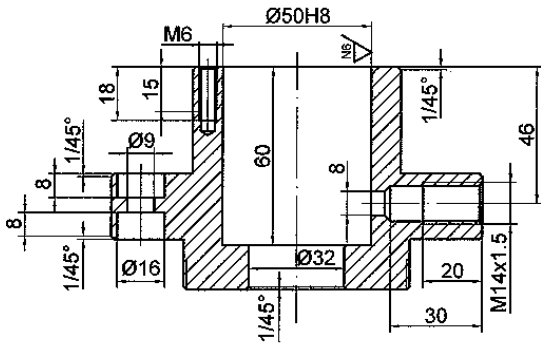
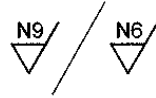

Tolerancije slobodnih mera		Površinska hrapavost		Površinska zaštita	
Materijal				Termička obrada	
		Masa		Razmera 1:2	
		Datum		Naziv:	
		Obradio Ivan		Telo	
		Nikolic			
		Stand.			
		Odobrio			
				Oznaka:	
				List	
St. l.	Izmene	Datum	Ime	Izv. pod.	Zamena za:

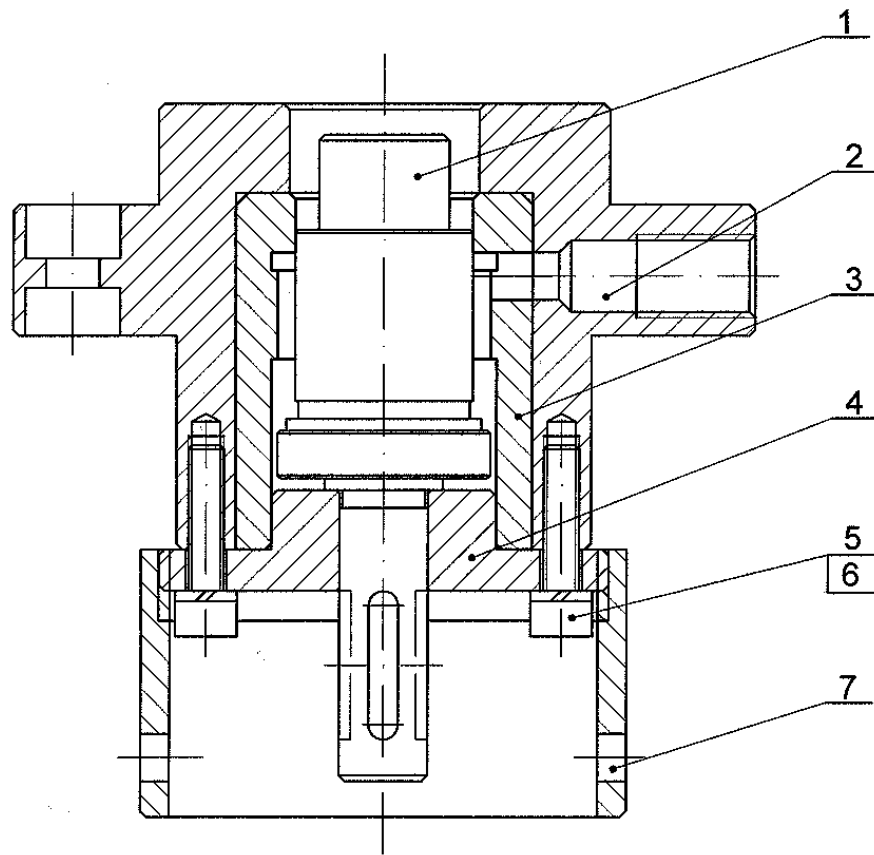

	7	Cev	1	Sipas 60	Ø90 x 25 x 50	
	6	Vijak	6	C V. 8.6	M6 x 20 JUS M.B1.120	
	5	El. podloška	6	C 2130	A6 JUS M.B2.110	
	4	Poklopac	1	C 0545	Ø80 x 22	
	3	Cilindar	1	Cu Sn 12	Ø55 x 65	
	2	Telo	1	C 0545	Ø130 x 80	
	1	Klip	1	C 1730	Ø40 x 115	

Merilo	Poz.	Naziv dela	Kom.	Materijal	Dimenzije	Br. crteža
--------	------	------------	------	-----------	-----------	------------

				Masa		Režmera 1:1									
<table border="1"> <tr><td>Datum</td><td></td></tr> <tr><td>Obradio</td><td>Ivan Nikolic</td></tr> <tr><td>Stand.</td><td></td></tr> <tr><td>Odobrio</td><td></td></tr> </table>				Datum		Obradio	Ivan Nikolic	Stand.		Odobrio		Naziv: Pneumatski klipni vibrator			
Datum															
Obradio	Ivan Nikolic														
Stand.															
Odobrio															
				Oznaka:		List									
<table border="1"> <tr><td>St. i.</td><td>Izmene</td><td>Datum</td><td>Ime</td></tr> </table>				St. i.	Izmene	Datum	Ime	Izv. pod.		Zamena za:					
St. i.	Izmene	Datum	Ime												